

**HITACHI**  
Inspire the Next

## Stallion Battery Charger

Range: Up to 1200 AMP



  
**stallion**  
Battery Charger



# Introduction

**Hitachi Hi-Rel Power Electronics Pvt. Ltd.** is in the business of Industrial UPS Systems since 1987 and has rich experience in supplying power back-up and power quality solutions for mission critical applications in refineries, petrochemicals, power generation, steel & metals, process industries as well as for critical data processing applications.

Hitachi Hi-Rel Power Electronics Pvt. Ltd. offers high quality power back-up technology and complete customized solutions for demanding applications.

## Battery Charger/DC UPS

The Stallion series of advanced battery chargers deploy Thyristor based technology and Digital Signal Processing Control (DSP) to achieve the desired DC output. Power required is adjusted by using phase control technology actuated by the DSP based control card. The DSP based control system enables user-friendly setting via the keypad on the front of the panel.

Stallion series battery chargers are designed for compatibility with all types of batteries-like-VRLA, NiCd, Plante, Lead acid tubular, Gel etc.

HHPE has supplied DC UPS /FC & FCBC charger for Power plant, process plant, hydro carbon industry and offshore projects.

## Design Philosophy

Proven Thyristor phase angle DC voltage control. It consists of transformer, semiconductor bridge rectifier, filters & load cut-off circuit.

The AC mains voltage is transformed to a suitable level and fed to the rectifier bridge which rectifies the AC input and feeds controlled DC output to the battery and load, through filter circuit.

Digital Signal Processor (DSP) based control for voltage and current.

## Human Interface Module

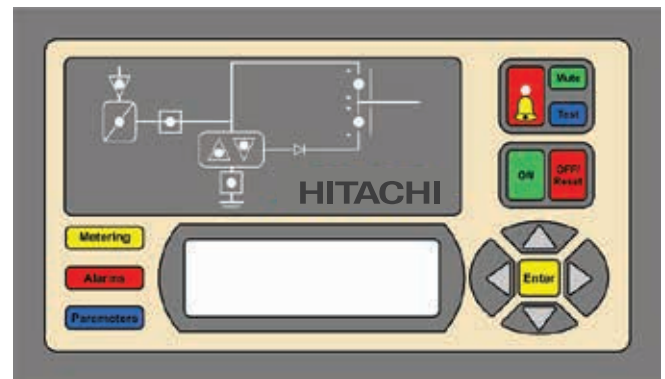

### AC to DC conversion :

The AC to DC Conversion element of the system is typically configured from Thyristor or switch mode technology depending on the performance and size constraints.

The range of Thyristor based systems are highly rugged industrial systems, suitable for the most demanding of environmental and operating conditions. The Thyristorised range of single phase and three phase input charger products capable of operating on 24 V to 360 V DC nominal voltage with output current up to 1200 AMP.

## Salient Features

- DSP based Digital control
- LCD Display + Keypad interface
- Comprehensive LED mimic
- Single or Parallel Redundant battery charger
- Auto temperature compensate battery charging
- Three mode of battery charging :
  - Auto float/ boost
  - Manual float / boost
  - Timer based boost
- Independent battery & load current limit
- Wide range of battery charger in standard and customized State of the art design and high quality standards ensure absolute reliability of the equipment
- Battery charger finds usage in mission critical applications like, process control, power station, switchgear protection, telecommunication tec.
- User friendly components layout for easy operation and maintenance date – time stamp event recording - last 999 events logged in non – volatile memory
- Battery charger is suitable with variety of battery types like, SMF, VRLA, LATB, LAPB, & Ultra low maintenance Ni Cd & Fiber plated Ni Cd battery
- Inbuilt Modbus , RS 232, RS 485 communication/ Facility.

# Technical Specifications

Advanced Battery Chargers with Thyristor based technology and DSP Control for precise DC output.

Charger Type	Stallion Battery Charger
Applicable Standard	IEC-62040-3
Charger Characteristics	Constant voltage / constant current with current limit
Control Technology	DSP based digital control, 6-Pulse Charger
Input Voltage	415Vac/230 Vac +15% to - 20%, Three phase (Optional : Single Phase Input)*
Input Frequency	50 Hz $\pm$ 10%
Output Voltage	24vDC, 48vDC, 110vDC, 120vDC, 220vDC, 240vDC, 360vDC
Output Current	Up to 1200AMP
Output Voltage Regulation	$\pm$ 1% of set value
Ripple Voltage	$\pm$ 1% RMS with battery connected $\pm$ 2% RMS without battery connected
Protection	Input Switch / MCCB with fuse Output MCB / MCCB Battery fuse / Switch / MCB / MCCB Current limit Soft start Overload protection Reverse polarity protection DC ground fault protection
Meters ( On LCD )	Input voltmeter Input current meter Input frequency meter Output voltmeter Battery charging / discharging current meter Load current
Indication	Input ON Charger ON Battery charging Battery discharging Battery Breaker ON
Alarms	Mains Low Mains High Charger Fail DC Low DC High DC earth fault Battery on Float mode Battery on Boost mode Charger over temperature
Operating Ambient Temperature	0 to 45°C
Altitude	1000 Meter from MSL
Atmosphere	Non-corrosive, Dust free, Freely ventilated
Audible Noise @ 1 Meter From Panel Front	55 dBA to 70 dBA (depending on system rating & configuration)
Enclosure Protection	IP-41 (IP-42**)
Type Of Cooling	Natural air cooling or forced air cooling
Paint Shade	RAL-7032, Epoxy powder coated (standard) Other shades on request
Dimensions	On request

\*Available up to 8kW output. | \*\* Optional.

## Options

- 12-Pulse Battery Charger
- Different Input Voltages
- Frequency : 60Hz
- RS-485, MODBUS, SNMP
- Paint shade : Other shades on request
- Redundant Cooling Fans
- DC Distribution Board
- Voltage Drop Diode
- 50°C Ambient Temp

# Single Line Diagram of Battery Charger

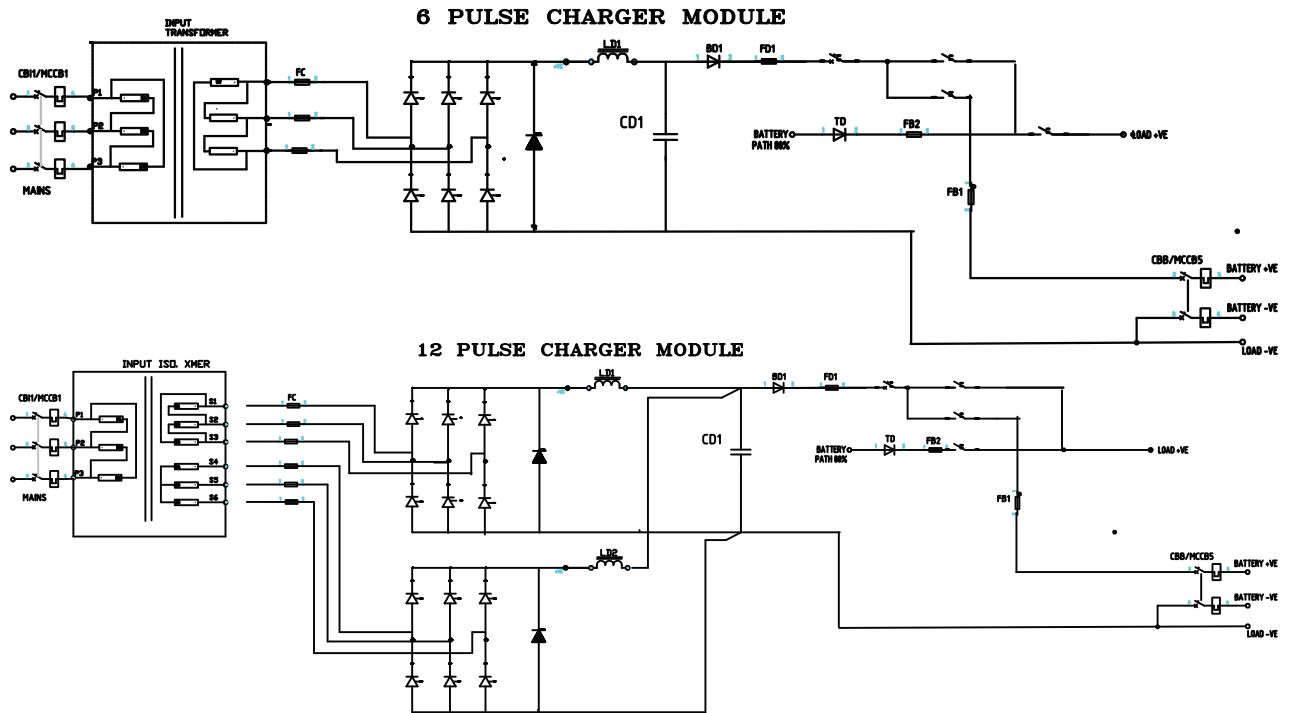

## Mode of Operation

### Float Cum Boost Charger - Single Load - Single Battery

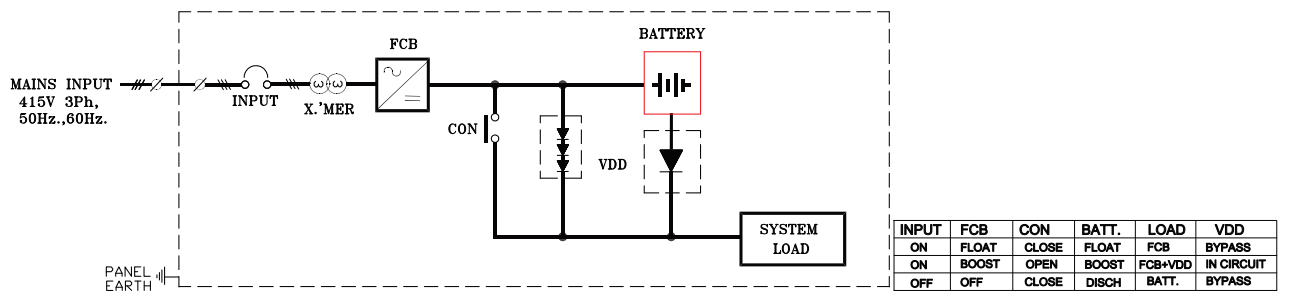

### Float and Float Cum Boost Charger - Single Load - Single Battery

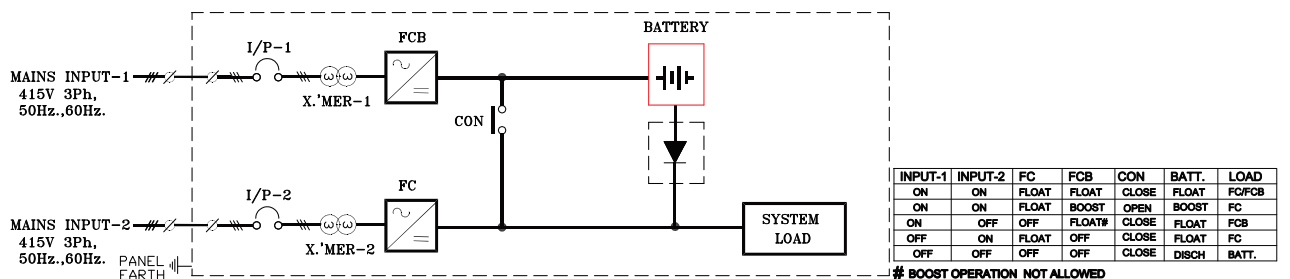

## Redundant Float Cum Boost Charger - Single Load - Single Battery

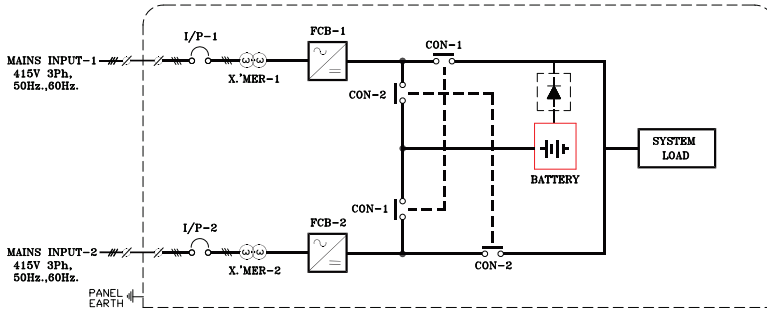

INPUT-1	INPUT-2	FCB-1	FCB-2	CON-1	CON-2	BATT.	LOAD
ON	ON	FLOAT	FLOAT	CLOSE	CLOSE	FLOAT	FCB-1/2
ON	ON	FLOAT#	BOOST	CLOSE	OPEN	BOOST	FCB-1
ON	ON	BOOST	FLOAT#	OPEN	CLOSE	BOOST	FCB-2
OFF	ON	OFF	FLOAT#	CLOSE	CLOSE	FLOAT	FCB-2
ON	OFF	FLOAT#	OFF	CLOSE	CLOSE	FLOAT	FCB-1
OFF	OFF	OFF	OFF	CLOSE	CLOSE	DISCH	BATT.

# BOOST OPERATION NOT ALLOWED

## Redundant Float Cum Boost Charger - Single Load - Dual Battery Bank

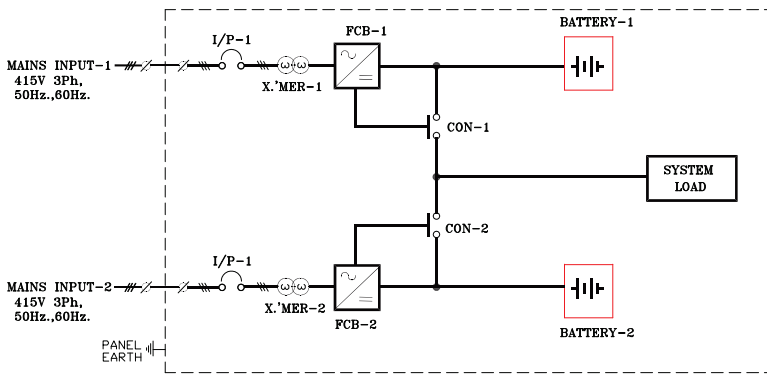

INPUT-1	INPUT-2	FCB-1	FCB-2	CON-1	CON-2	BATT.-1	BATT.-2	LOAD
ON	ON	FLOAT	FLOAT	CLOSE	CLOSE	FLOAT	FLOAT	FCB-1
ON	ON	FLOAT	BOOST	CLOSE	OPEN	FLOAT	BOOST	FCB-1
ON	ON	BOOST	FLOAT#	OPEN	CLOSE	BOOST	FLOAT	FCB-2
OFF	ON	OFF	FLOAT#	CLOSE	CLOSE	FLOAT	FLOAT	FCB-2
ON	OFF	FLOAT#	OFF	CLOSE	CLOSE	FLOAT	FLOAT	FCB-1
OFF	OFF	OFF	OFF	CLOSE	CLOSE	DISCH	DISCH	BATT.-1/2

# BOOST OPERATION NOT ALLOWED

## Redundant Float Cum Boost Charger - Dual Load - Dual Battery Bank

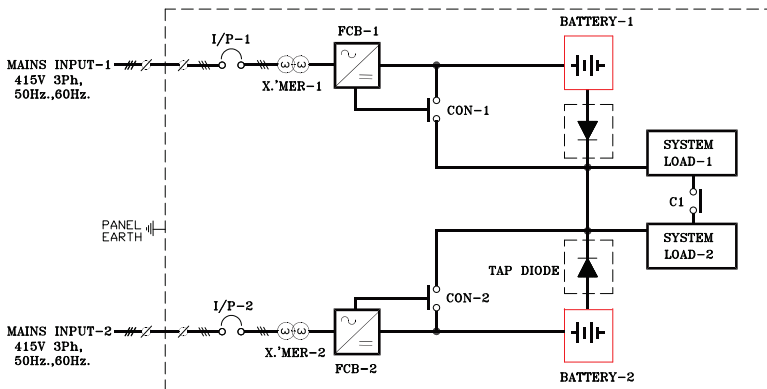

INPUT-1	INPUT-2	FCB-1	FCB-2	CON-1	CON-2	BATT.-1	BATT.-2	LOAD-1	LOAD-2
ON	ON	FLOAT	FLOAT	CLOSE	CLOSE	FLOAT	FLOAT	FCB-1	FCB-2
ON	ON	FLOAT#	BOOST	CLOSE	OPEN	FLOAT	BOOST	FCB-1	FCB-2
ON	ON	BOOST	FLOAT#	OPEN	CLOSE	BOOST	FLOAT	FCB-2	FCB-1
OFF	ON	OFF	FLOAT#	CLOSE	CLOSE	DISCH	FLOAT	BATT.-1	FCB-2
ON	OFF	FLOAT#	OFF	CLOSE	CLOSE	FLOAT	DISCH	FCB-1	BATT.-2
OFF	OFF	OFF	OFF	CLOSE	CLOSE	DISCH	DISCH	BATT.-1	BATT.-2

# BOOST OPERATION NOT ALLOWED

\$\$ THROUGH BUS COUPLER

# Communication Feature

- 2 lines with 16 characters (standard version for English characters) and 12 keys (the function is described for each operating mode) using LCD.
- MCR is a DC UPS Monitoring Software which supports the multiple DC UPS connected in the RS-485 network to the local computer system.
- MCR will automatically search & Monitor the DC UPS devices connected in the network.
- MCR can provide the overview details of all the DC UPS connected in network with the same window provides all information at glance.
- MCR can provide detailed view about all information of the DC UPS such as main's Input, Output, Inverter, Load, Battery data. The information is shown in the same window.
- The functionality of collecting all the information about Alarms occurs in DC UPS and alerting by giving Alarm when it comes. These alarms are came with instant information like their date, time and other properties too.
- With the functionality of data logging (DC UPS metering parameter) MCR provides last 30 days data of each DC UPS.

## Event Log

Sr. No.	Date	Time	Event Name
1	12/11/2008	13:16:43	MANUAL BOOST
2	12/11/2008	13:16:00	BATT DISCHARGE*
3	12/11/2008	13:14:36	LOW BATT*
4	12/11/2008	13:13:58	LOW BATT TRIP*
5	12/11/2008	13:13:12	MAINS FREQ O TOL*
6	12/11/2008	13:12:11	I/P PHASE OUT*
7	12/11/2008	13:07:43	MAINS LOW*
8	12/11/2008	13:06:56	MAINS FAIL*
9	12/11/2008	13:05:11	LOW BATT TRIP
10	12/11/2008	13:03:13	LOW BATT
11	12/11/2008	13:02:25	BATT DISCHARGE
12	12/11/2008	13:02:11	CHG OFF
13	12/11/2008	12:13:49	MAINS FAIL
14	12/11/2008	12:13:33	MAINS FREQ O TOL
15	12/11/2008	12:13:21	I/P PHASE OUT
16	12/11/2008	12:12:50	MAINS LOW

## Metering Display Information

### Main's Input

	Voltage	Current	Frequency
R-Y Phase	385 Volt	40 AMP	49.85 Hz
Y-B Phase	385 Volt	40 AMP	49.85 Hz
B-R Phase	385 Volt	40 AMP	49.85 Hz

### Output

DC	Current
220 Volt	1000 AMP

### Battery

Current	Status	Mode
0.2 AMP	Charging	Float

### Load

In kW	Load(%)
10 kW	10%

### Total Load

In kW	Load(%)
12kW	12%

## Applications

- Telecommunication Systems.
- Power Plant (Generation, Transmission, Distribution).
- Manufacturing Industries.
- Railways.
- Critical DC Requirements.
- Oil & Gas Industries.
- Fertilizer and Petrochemical Industries.

## Battery Charger Rating

Current (Amp)	24 V	48 V	110 V	220 V	360 V
5	SBC10240005	SBC10480005	SBC11100005	SBC12200005	SBC33600005
10	SBC10240010	SBC10480010	SBC11100010	SBC12200010	SBC33600010
15	SBC10240015	SBC10480015	SBC11100015	SBC32200015	SBC33600015
20	SBC10240020	SBC10480020	SBC11100020	SBC32200020	SBC33600020
25	SBC10240025	SBC10480025	SBC31100025	SBC32200025	SBC33600025
30	SBC10240030	SBC30480030	SBC31100030	SBC32200030	SBC33600030
40	SBC10240040	SBC30480040	SBC31100040	SBC32200040	SBC33600040
50	SBC10240050	SBC30480050	SBC31100050	SBC32200050	SBC33600050
60	SBC30240060	SBC30480060	SBC31100060	SBC32200060	SBC33600060
70	SBC30240070	SBC30480070	SBC31100070	SBC32200070	SBC33600070
80	SBC30240080	SBC30480080	SBC31100080	SBC32200080	SBC33600080
90	SBC30240090	SBC30480090	SBC31100090	SBC32200090	SBC33600090
100	SBC30240100	SBC30480100	SBC31100100	SBC32200100	SBC33600100
150	SBC30240150	SBC30480150	SBC31100150	SBC32200150	SBC33600150
200	SBC30240200	SBC30480200	SBC31100200	SBC32200200	SBC33600200
250	SBC30240250	SBC30480250	SBC31100250	SBC32200250	SBC33600250
300	SBC30240300	SBC30480300	SBC31100300	SBC32200300	SBC33600300
350	SBC30240350	SBC30480350	SBC31100350	SBC32200350	SBC33600350
400	SBC30240400	SBC30480400	SBC31100400	SBC32200400	SBC33600400
450	SBC30240450	SBC30480450	SBC31100450	SBC32200450	SBC33600450
500	SBC30240500	SBC30480500	SBC31100500	SBC32200500	SBC33600500
550	SBC30240550	SBC30480550	SBC31100550	SBC32200550	SBC33600550
600	SBC30240600	SBC30480600	SBC31100600	SBC32200600	SBC33600600
650	SBC30240650	SBC30480650	SBC31100650	SBC32200650	SBC33600650
700	SBC30240700	SBC30480700	SBC31100700	SBC32200700	SBC33600700
800	SBC30240800	SBC30480800	SBC31100800	SBC32200800	SBC33600800
1000	SBC30241000	SBC30481000	SBC31101000	SBC32201000	SBC33601000
1200	SBC30241200	SBC30481200	SBC31101200	SBC32201200	SBC33601200

STALLION BATTERY CHARGER(SBC) -PHASE -VOLTAGE -CURRENT

## Selection Chart

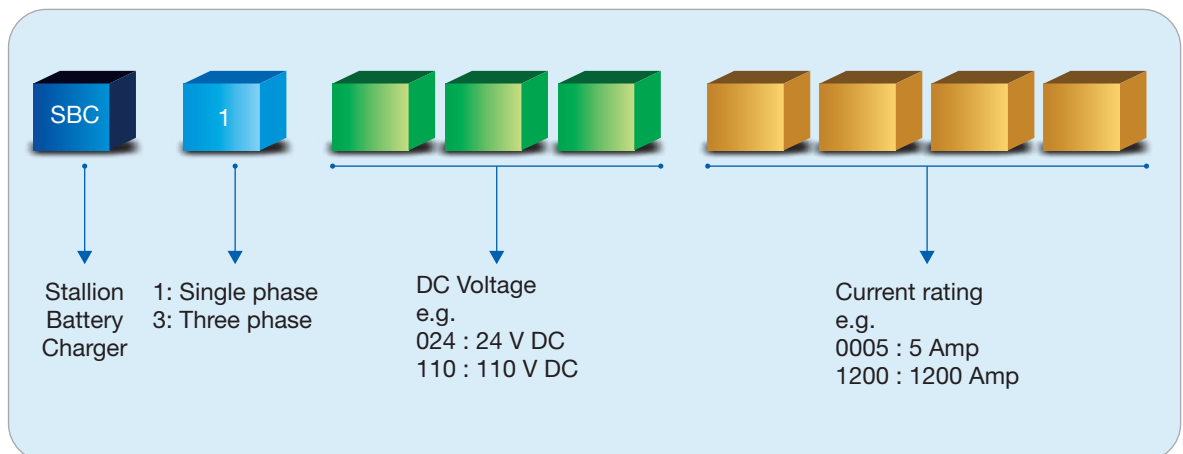

**Hitachi Australia Pty. Ltd.**

Suite 801, Level 8, 123, Epping Road, North Ryde NSW 2113  
Phone: +61 2 9888 4100 Fax: +61 2 9888 4188  
Web: [www.hitachi.com.au](http://www.hitachi.com.au)

In the spirit of continuous improvement, specifications are subject to change without notice.

